

NOTE:  
GREEN LED ON  
SIGNIFIES  
CARRIER  
ARRIVAL

RED LED ON  
SIGNIFIES  
SYSTEM IN USE

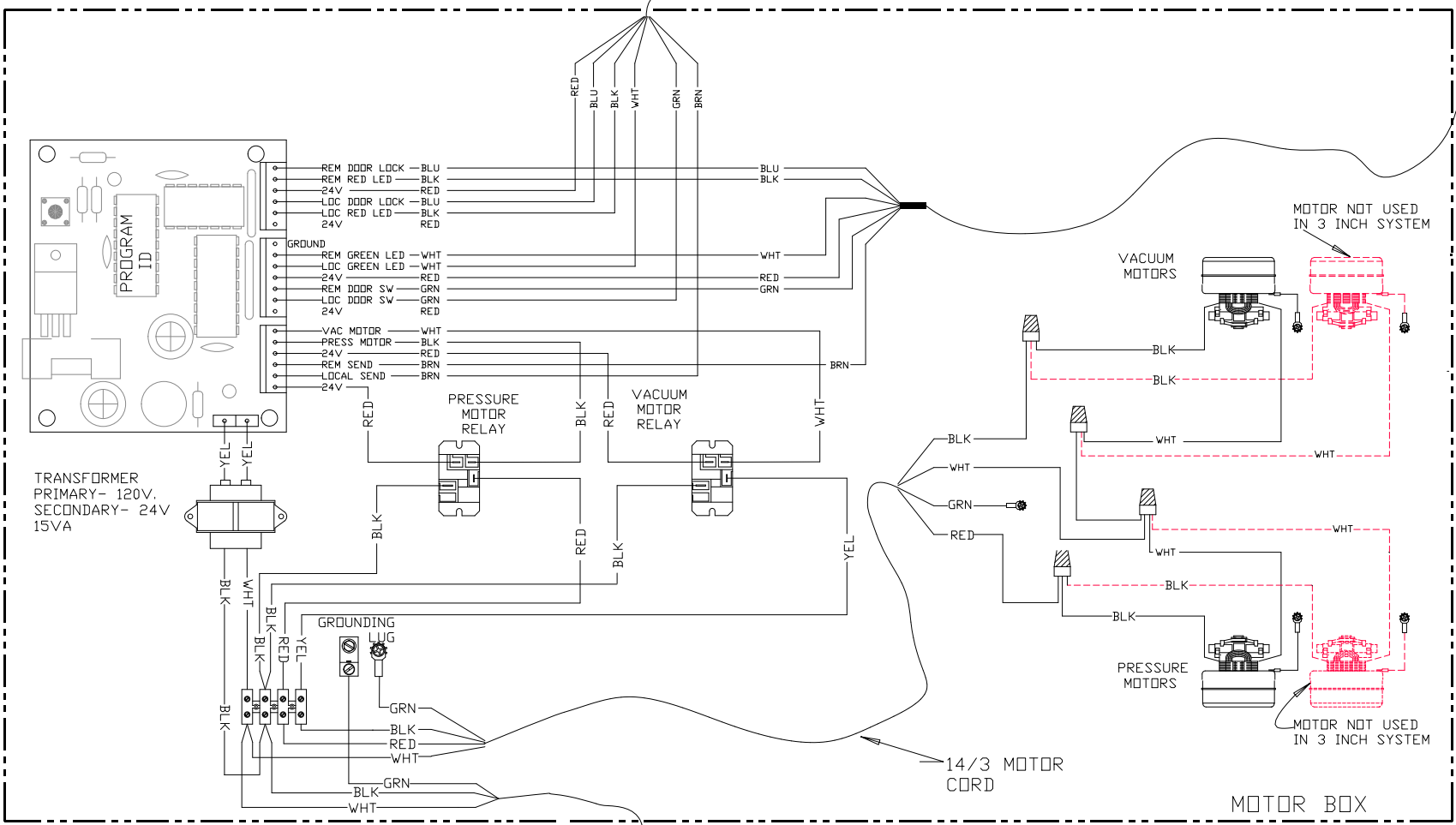

6 CONDUCTOR PERIPHERAL CABLE

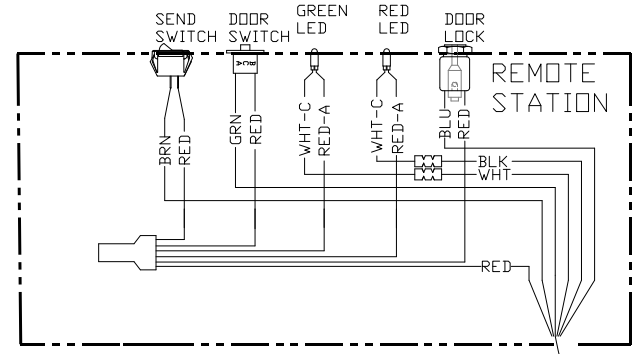

INFORMATION CONTAINED HEREIN IS PROPRIETARY TO EAGLE PNEUMATIC, INC ALL RIGHTS RESERVED.

TOLERANCES:  
UNLESS OTHERWISE SPECIFIED  
FRACTIONS +/-1/32"  
DECIMALS +/-0.005"

REVISIONS:

1-10/30/02	6-07/24/03
2-10/31/02	7-10/26/06
3-04/10/03	8-04/04/07
4-04/21/03	9-01/05/11
5-07/07/03	10-10/06/13

DRAWN BY: JAC/DTS

DATE:10/30/02

NAME:  
WIRING DIAGRAM  
MINI MARK II  
M2 PCB  
REMOTE ARRIVAL  
INDICATORS

TO SECURE GROUNDING LUG TO FRAME USE #10 SHEET METAL SCREW. USE UL LISTED GROUND LUG.

POWER CORD

NOTE:  
PLUG IS NOT SUITABLE AS A DISCONNECT. USER MUST SUPPLY A SUITABLE DISCONNECT.

VOLTAGE-120VAC  
14 AMPS  
1 HP SINGLE PHASE/50/60 Hz.

20 AMP BRANCH CIRCUIT PROTECTION TO BE PROVIDED BY OTHERS DURING FIELD INSTALLATION.

OPTIONS	

PART NO.

E-11881-2

CADFILE: A20