

NOTE:
GREEN LED ON
SIGNIFIES
CARRIER
ARRIVAL

RED LED ON
SIGNIFIES
SYSTEM IN USE

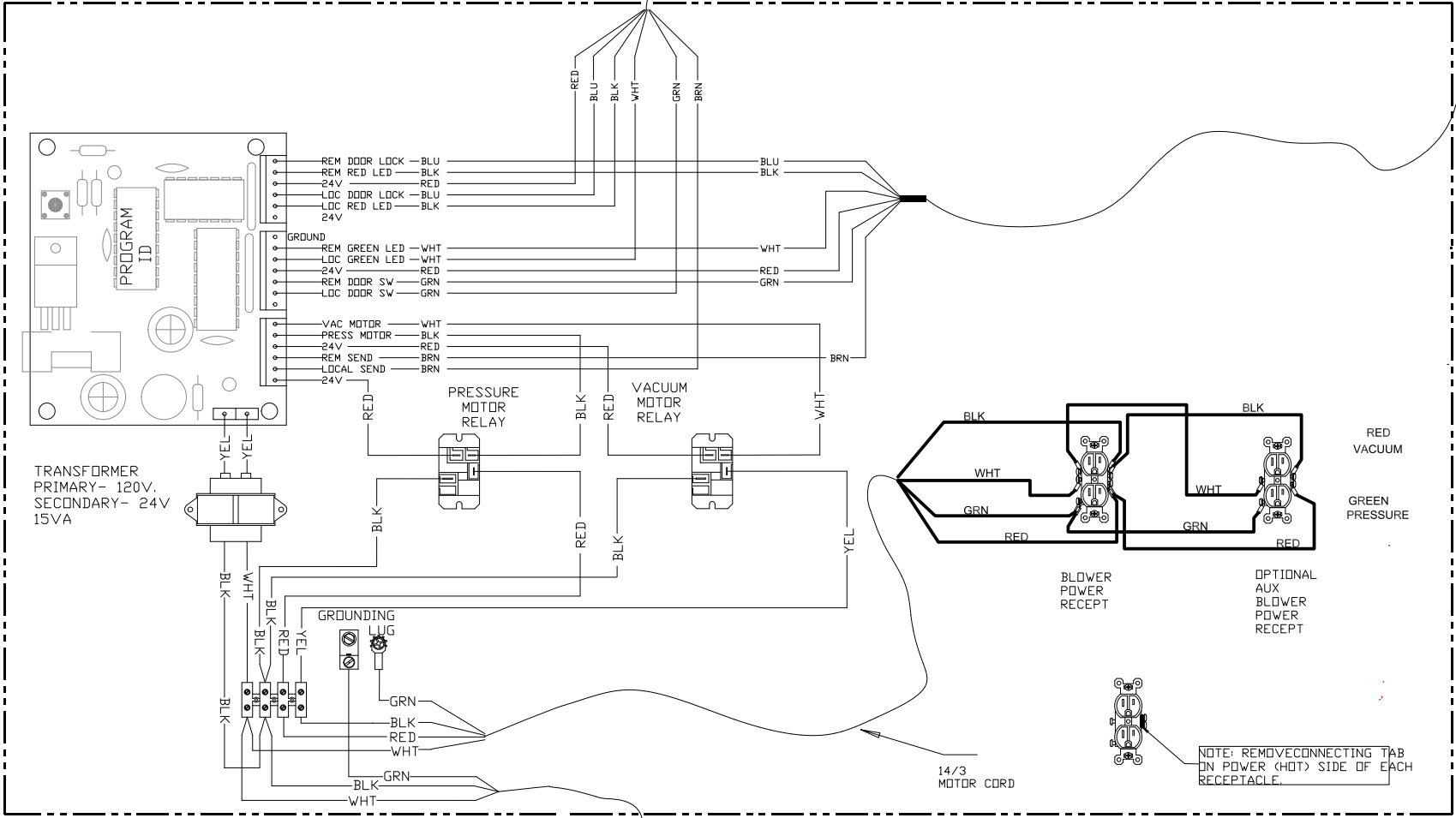

6 CONDUCTOR PERIPHERAL CABLE

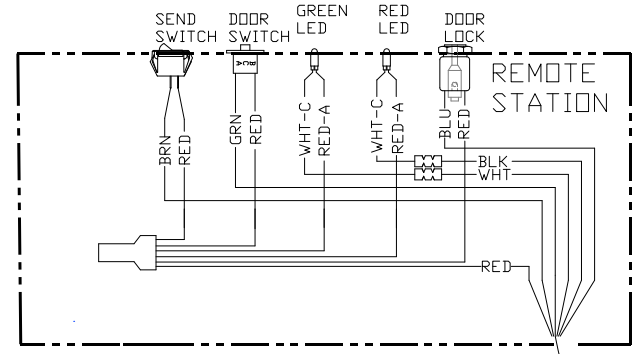

INFORMATION CONTAINED HEREIN IS PROPRIETARY TO EAGLE PNEUMATIC, INC ALL RIGHTS RESERVED.

TOLERANCES:
UNLESS OTHERWISE SPECIFIED
FRACTIONS +/-1/32"
DECIMALS +/- .005"

REVISIONS:

DRAWN BY: DTS

DATE: 02/23/15

NAME:
RETROFIT KIT
MINI MARK II
PRESSURE/VACUUM
14 AMP

PART NO.
E-11881-2-C

CAD FILE: A20

TO SECURE GROUNDING LUG TO FRAME USE #10 SHEET METAL SCREW. USE UL LISTED GROUND LUG.

VOLTAGE-120VAC
14 AMPS
1 HP SINGLE PHASE/50/60 Hz.

POWER CORD

NOTE:
PLUG IS NOT SUITABLE AS A DISCONNECT. USER MUST SUPPLY A SUITABLE DISCONNECT.

20 AMP BRANCH CIRCUIT PROTECTION TO BE PROVIDED BY OTHERS DURING FIELD INSTALLATION.

NOTE: REMOVE CONNECTING TAB ON POWER (HOT) SIDE OF EACH RECEPTACLE.