

NOTE:
GREEN LED ON
SIGNIFIES
CARRIER
ARRIVAL

RED LED ON
SIGNIFIES
SYSTEM IN USE

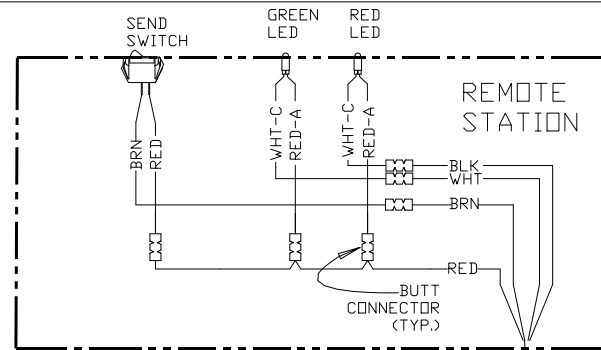

6 CONDUCTOR
CABLE

6 CONDUCTOR
PERIPHERAL
CABLE

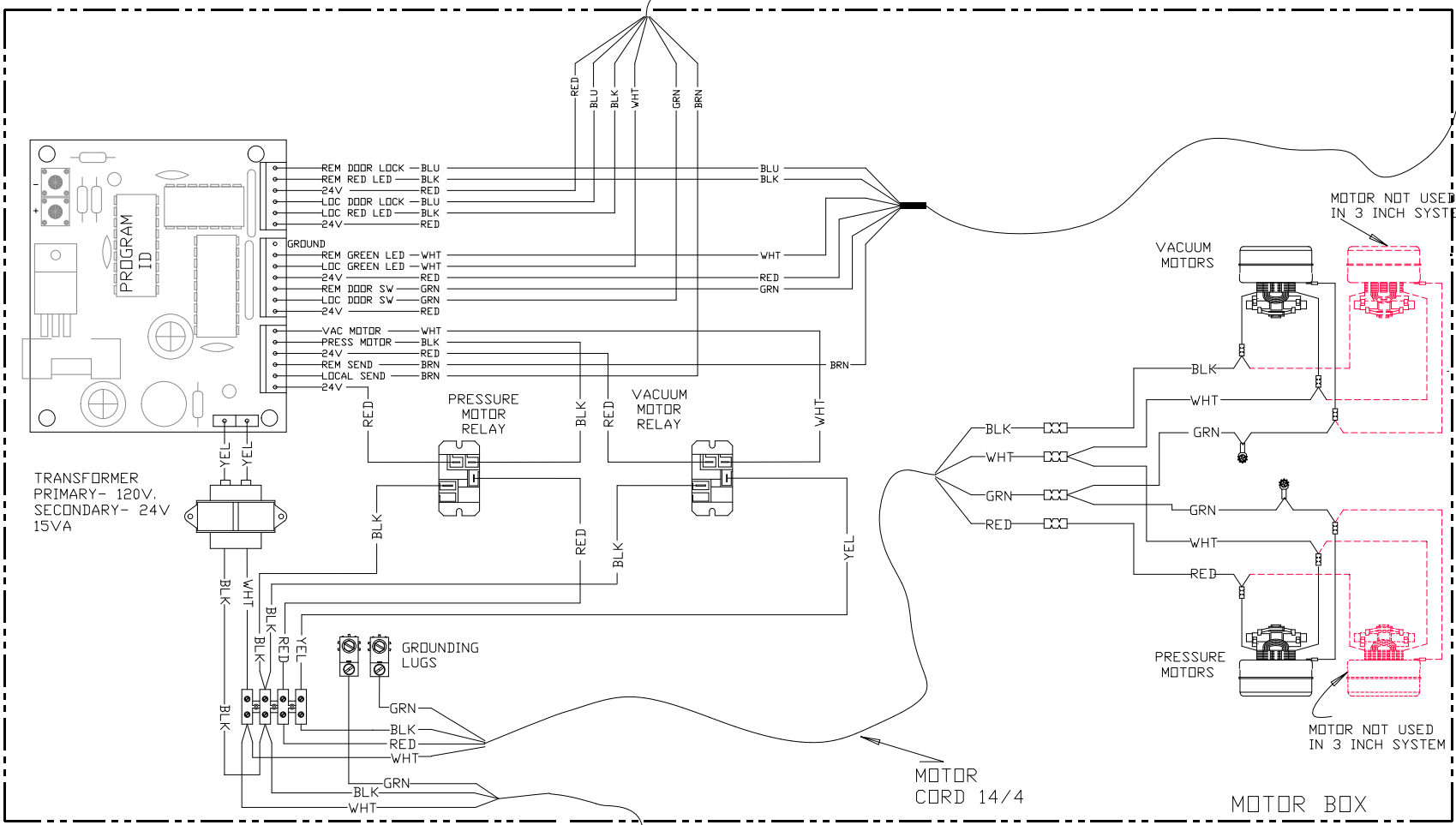

INFORMATION
CONTAINED HEREIN
IS PROPRIETARY TO
EAGLE PNEUMATIC,
INC ALL RIGHTS
RESERVED.

TOLERANCES:
UNLESS OTHERWISE SPECIFIED
FRACTIONS +/-1/32"
DECIMALS +/-0.005"

REVISIONS:

1-10/30/02	6-07/24/03
2-10/31/02	7-10/26/06
3-04/10/03	8-04/04/07
4-04/21/03	9-01/05/11
5-07/07/03	

DRAWN BY: JAC/DTS

DATE: 10/30/02

NAME:
WIRING DIAGRAM
MINI MARK II
M2 PCB
RETRO-FIT
KIT FOR
MESSENGER

PART NO.

E-11881-2-B

CADFILE: A20

TO SECURE GROUNDING LUGS TO FRAME
USE #10 SHEET METAL SCREW.
USE UL LISTED GROUND LUG (x2).

POWER
CORD 14/3

NOTE:
PLUG IS NOT SUITABLE
AS A DISCONNECT.
USER MUST SUPPLY
A SUITABLE DISCONNECT.

VOLTAGE-120VAC
14 AMPS
1 HP SINGLE PHASE/50/60 Hz.

20 AMP BRANCH CIRCUIT
PROTECTION TO BE
PROVIDED BY OTHERS
DURING FIELD INSTALLATION.

OPTIONS	
-B	RETRO-FIT KIT FOR MESSENGER